

PRELIMINARY

PART NUMBER	SSL-LX509FT3USBD-B	REV	X1
REV	E.C.N. NUMBER AND REVISION COMMENTS	DATE	
X1	-	06.30.23	

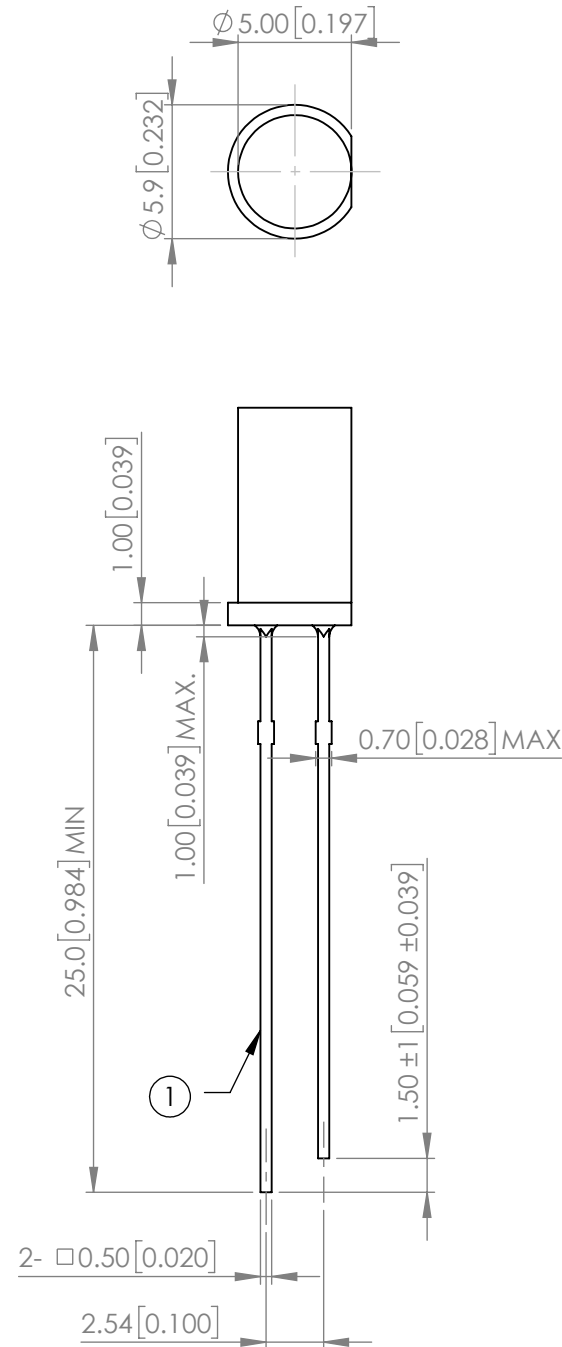

POLARITY

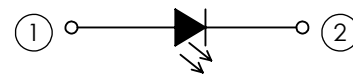

ELECTRO-OPTICAL CHARACTERISTIC TA=25°C

PARAMETER	MIN	TYP	MAX	UNITS	TEST COND
PEAK WAVELENGTH	-	460	-	nm	If=20mA
FORWARD VOLTAGE	-	3.3	4.0	Vf	If=20mA
REVERSE CURRENT	-	-	10	uA	VR=5V
LUMINOUS INTENSITY	-	50	-	mcd	If=20mA
VIEWING ANGLE	-	140	-	2x theta1/2	-
EMITTED COLOR	BLUE				
EPOXY LENS FINISH	WHITE DIFFUSED				

ABSOLUTE MAXIMUM RATINGS TA=25°C

PARAMETER	MAX	UNITS
PEAK FORWARD CURRENT*	150	mA
FORWARD CURRENT	30	mA
REVERSE VOLTAGE	5	V
POWER DISSIPATION	120	mW
STORAGE TEMPERATURE	-40 TO +85	°C
OPERATING TEMPERATURE	-40 TO +85	°C
SOLDERING TEMPERATURE**	3 SEC. MAX.@260	°C

*1/10 DUTY CYCLE, 0.1ms PULSE WIDTH

**2.0mm FROM BODY

STATIC DEVICE FOLLOW PROPER E.S.D. HANDLING PROCEDURES WHEN WORKING WITH THIS PART

*UNLESS OTHERWISE SPECIFIED TOLERANCES PER DECIMAL PRECISION ARE: X=±1 (±0.039), X.X=±0.5 (±0.020), X.XX=±0.25 (±0.010), X.XXX=±0.127 (±0.005). LEAD SIZE=±0.05 (±0.002), LEAD LENGTH=±0.75 (±0.030). MIN= ^{+DECIMAL PRECISION}/_{-0.00} MAX.= ^{+0.00}/_{-DECIMAL PRECISION}

<p>425 N. GARY AVE. CAROL STREAM, IL 60188 PHONE : 800-278-5666 FAX : 630-315-2150 WEB : WWW.LUMEX.COM</p>	<p>∅5.0*9.6H(mm) FLAT TOP, 470nm BLUE LED, WHITE DIFFUSED LENS.,</p>	DATE : 2023.06.30	DRAWN BY : E.C.
	<p>**THE SPECIFICATIONS MAY CHANGE AT ANY TIME WITHOUT NOTICE.**</p>	PAGE : 1 OF 1	CHKD BY : T.S.
	<p>CONFIDENTIAL INFORMATION THE INFORMATION CONTAINED IN THIS DOCUMENT IS THE PROPERTY OF LUMEX INC. EXCEPT AS SPECIFICALLY AUTHORIZED IN WRITING BY LUMEX INC., THE HOLDER OF THIS DOCUMENT SHALL KEEP ALL INFORMATION CONTAINED HEREIN CONFIDENTIAL AND SHALL PROTECT SAME IN WHOLE OR IN PART FROM DISCLOSURE AND DISSEMINATION TO ALL THIRD PARTIES.</p>	SCALE : NTF	APRVD BY : --
		UNIT : mm [INCH]	